



Product Catalogue ODYSSEY

Light Commercial Split Systems

75-250 MBH / 20-75 kW
Cooling Only
50Hz



SS-PRC025-EN

Contents

Model Number Description	1-2
Features	3
General Data	4
Performance Data	5
Fan Performance Table	6-7
Condensing Unit Performing Curves	8
Application Consideration	9
Dimensional Data	10-13
System Wiring	14-15
System Integration	16
Mechanical Specification	17-18



Model Number Description

TTA Model Nomenclature

T T A 0 7 5 S D 1 X A 0 S A B
 1 2 3 4 5 6 7 8 9 10 11 12 13 14 15

DIGIT 1,2	T T	Condensing Unit / Cooling only
DIGIT 3	A	Air Cooled
DIGIT 4,5,6	0 7 5	Nominal Cooling Capacity, MBH 075 = 84 MBH 100 = 106 MBH 125 = 127 MBH
DIGIT 7	S	Development Sequence
DIGIT 8	D	Electrical Rating / Utilization Range D = 380 - 415V / 3Phase / 50 Hz
DIGIT 9	1	Factory Mounted Control 1 = DOL Starter
DIGIT 10	X	Factory Installed Option X = None F = Corrosion Resistant Fin G = Coll Guard Assembly H = F & G
DIGIT 11	A	Refrigerant Type A = R22 B = R407C
DIGIT 12	0	Future Use
DIGIT 13	S	Operating Ambient S = Standard Ambient H = High Ambient Option
DIGIT 14	A	Minor Design Sequence
DIGIT 15	B	Service Indicator



Model Number Description

MCDP Model Nomenclature.

M C D P 0 7 5 B 1 0 0 0 0 A A
 1 2 3 4 5 6 7 8 9 10 11 12 13 14 15

- DIGIT 1,2,3 M C D InDoor Unit, Horizontal Discharge / Cooling Only
- DIGIT 4 P Development Sequence
- DIGIT 5,6,7 0 7 5 Nominal Cooling Capacity, MBH
 075 = 75 MBH
 100 = 100 MBH
 125 = 125 MBH
- DIGIT 8 B Electrical Rating / Utilization Range
 B = 220 - 240V / 1 Ph / 50Hz
- DIGIT 9 1 Factory Mounted Control
 1 = DOL Starter c/w Temperature Controller
- DIGIT 10 0 Future Use
- DIGIT 11 0 Future Use
- DIGIT 12 0 Future Use
- DIGIT 13 0 Future Use
- DIGIT 14 A Minor Design Sequence
- DIGIT 15 A Service Indicator

MCDP Models	MTR, Kw
MCDP 075	D = 0.75
MCDP 100 / 125	E = 1.1

TTH Model Nomenclature.

T T H 1 2 5 Q D 1 D 0 0 0 B A
 1 2 3 4 5 6 7 8 9 10 11 12 13 14 15

- DIGIT 1,2 T T InDoor Unit / Cooling Only
- DIGIT 3 H Air Flow Configuration
 H = Horizontal Discharge
 V = Vertical Discharge
- DIGIT 4,5,6 1 5 0 Nominat Cooling Capacity, MBH
 150 = 150 MBH 200 = 200 MBH
 175 = 175 MBH 240 = 240 MBH
- DIGIT 7 Q Development Sequence
- DIGIT 8 D Electrical Rating / Utilization Range
 D = 380 - 415V / 3Phase / 50 Hz
- DIGIT 9 1 Factory Mounted Control
 1 = DOL Starter c/w Temperature Controller
- DIGIT 10 G Installed Motor kW
- DIGIT 11 0 Future Use
- DIGIT 12 0 Future Use
- DIGIT 13 0 Future Use
- DIGIT 14 B Minor Design Sequence
 B = Second. (Year 2006, TTH/BDHB Casing Rationalization)
- DIGIT 15 A Service Indicator

TTH Models	Std. MTR, kW	Oversize MTR; kW
TTH 150/175	G = 2.2	J = 4.0
TTH 200	H = 3.0	K = 5.5
TTH 240	J = 4.0	K = 5.5

Features

The Odyssey air cooled Split System from Trane offers the latest technology available for today's flexible and demanding market needs. It offers the optimum answer from standard everyday applications to customized installations.

Its design follows the "Plug and Play" concept to offer easy installation, maintenance, and project management.

Far beyond effective cooling, the Odyssey Splits provided unparalleled benefits in terms of:

- Versatility
- Reliability
- Simplicity

Everything is in the box

Only a main power supply, low voltage control interfacing refrigerant piping and charge are necessary, as the rest are in the "box".

This includes unit mounted starters, PCB board and wall thermostat.

Low installation costs cuts time and saves space

The Odyssey's fully packaged concept centers on the philosophy to reduce installation time and costs as well as reduce overall system defects from product to installation in order to deliver a defect free product to the customer. From the smaller 1 phase indoor units to the modular condensing units, designs are tuned to current market needs where space is a premium.

Flexibility

Flexible standard systems do not stop here. Outdoor condensing units can be matched with virtually an unlimited combination of Trane AHUs; from 100% fresh air units, to outdoor AHUs, standby systems and even high ambient installations.

Scroll Compressors Reliability

Scroll compressors have simple mechanical design with only three major moving parts.

Scroll type compression provides inherently low vibration. Scroll compliance provides a completely enclosed compression chamber which leads to increased efficiency.

Compressor FEATURES

Compliant Scroll

- High Efficiency
- Better Liquid Handling
- Better Debris Handling
- Self-compensating for wear ("Wears-in" vs. "Wears-out")
- 70% fewer moving parts
- Low sound level

internal Line Break Motor Protection

Suction Gas Motor Cooling

Suction Screen

Disc Type Check Valve

Centrifugal Oil Pump with Filter and Magnet

DU (PTFE) Journal Bearings

Low Shutdown Noise





General Data

Odyssey Condensing Units General Data

		TTA 075	TTA 100	TTA 125	2xTTA 075	TTA075+100	2xTTA 100	TTA100+125	2xTTA125
Performances (1)									
Gross Cooling Capacity (1)	(kW)(MBH)	25 84	31.0 106	37 127	49 168	56 190	62 212	68 233	74 254
Unit Capacity Steps (%)		0-100	0-100	0-100	0-50-100	0-50-100	0-50-100	0-50-100	0-50-100
Total Compressor Power Input (1)	(kW)	6.9	9.1	10.2	13.8	16.0	19.3	19.3	20.4
Main Power Supply		400/3/50	400/3/50	400/3/50	400/3/50	400/3/50	400/3/50	400/3/50	400/3/50
Utilization Range		400V+, -10%							
Compressor									
Number		1	1	1	2	2	2	2	2
Type		Hermetic Scroll							
Unit MCA Amps (4)	(A)	21.7	21	24					
RLA / LRA (2)	(A)	12.4/95	15.9/125	17.9/125					
Motor RPM	(rpm)								
Sump Heater (Optional) per compressor (W)									
Liquid and Suction connection									
Suction Connection	brazed	1 1/8"	1 1/8"	1 1/8"	1 1/8"	1 1/8"	1 1/8"	1 1/8"	1 1/8"
Liquid Connection	brazed	1/2"	1/2"	1/2"	1/2"	1/2"	1/2"	1/2"	1/2"
Coil									
Type		Plate Fin							
Tube Size	(mm)	9.52							
Tube Type		Smooth							
Height	(mm)	914							
Length	(mm)	965							
Quantity [per TTA]		2	2	2	2	2	2	2	2
Face Area [per TTA]	(m2)	1.77	1.77	1.77	1.77	1.77	1.77	1.77	1.77
Rows [std. Ambient]		1	2	2	1	1 & 2	2	2	2
Fins Per Foot (fpf)		168	144	168	168	168 & 144	144	144 & 168	168
Fan									
Type		Propeller							
Number		1	1	1	2	2	2	2	2
Diameter	(mm)/(in)	650 26	650 26	650 26	650 26	650 26	650 26	650 26	650 26
Drive Type		Direct Drive, 3 Phase							
Speeds Number		1	1	1	1	1	1	1	1
Air Flow	(m3/h)/(cfm)	15200/9535	15700/9240	15400/9064	32400/19070	31899/18775	31899/18480	31099/18304	30800/18128
Motors Quantity		1	1	1	2	2	2	2	2
Motors kW (2)	kW/hp					0.55/0.75			
FLA / LRA (2)	(A)					1.8/5.66			
Motor RPM	(rpm)					910			
Dimensions									
Height	(mm)	945							
Width	(mm)	1115							
Length	(mm)	935							
Weight Crated	(kg)	165	197	230	330	352	394	427	460
System Data									
Refrigerant Circuit [per TTA]		1	1	1	1	1	1	1	1
Refrigerant Charge (3)									
Approximate per circuit	(kg)	7.8	8.8	9.5					
TTA Only									

Notes

- [1] at 7deg C SSt and 35 deg C Ambient, 420V,
- [2] Per Motor @ 400V
- [3] Per Circuit

- [4] Minimum Circuit Ampacity (MCA) is 125% of the largest compressor RLA plus 100% of the other compressor RLA plus the sum of the condenser fan FLA.
- [5] Standard Ambient range of up to 45 C, with high ambient range of up to 50deg C with the HA Option.

Odyssey Air Handling Units General Data

		MCDP075	MCDP100	MCDP125	TTH-V 150	TTH-V 175	TTH-V 200	TTH-V 240
Evaporator Coil								
Evaporator Rated Air Flow [MCDs at Med, Speed	Cfm	2400	3225	3237	4750	5300	6500	8000
	Cmh	4078	5479	5500	8070	9005	11044	13592
@ Available ESP at nominal Airflow	Pg	163	111	111	125	125	188	188
	Hign Pa [3]	263	248	248				
	Med. Pa [3]	182	238	238				
	Low. Pa [3]	51	158	158				
Configuration (1)		H	H	H	H and V	H & V	H & V	H & V
Face Area	Sg. ft/m2	5/0.46	6.7/0.62	6.7/0.62	10.22/0.95	10.22/0.95	15/1.39	15/1.39
Tube Material		COPPER						
Tube Type		SMOOTH BORE						
Tube Size (OD)	in/mm	3/8in-9.52mm						
Rowas/FPF		3/144	3/144	4/144	3/144	3/144	3/144	3/144
No. Of Circuits		1	1	1	2	2	2	2
Refrigerant Flow Control		FLOW CONTROL			THERMAL EXPANSION VALVE			
Drain Connection Size	in	3/4	3/4	3/4	1.0	1.0	1.0	1.0
Evaporator Fan/Motor								
Motor	Drive Type	DIRECT-DRIVE, 3 Speed,			BEL-DRIVEN, TEFC			
Utilization Range		240V, 50 Hz, 1 Phase			400V+, -10%, 50Hz, 3 Phase			
FLA (each) (2)	(Hi/Med/Low) (3)	5.8/5.5/4.4	9/8.5/7.5	9/8.5/7.5	4.70	4.70	6.20	8
LRA		12.1/8.9/7	23.8/16.9/13	23.8/16.9/13	29.40	29.40	40.20	38.20
	Std. kW	0.75	1.1	1.1	2.2	2.2	3	4.0
Diameter of Fan	in/mm	9/229	9/229	9/229	15/361	15/381	18/457	18/457
Width of Fan	in/mm	7/176	9/229	9/229	15/361	15/381	18/457	18/457
No of Fans		1	2	2	1	1	1	1
Indoor Fan Type								
Nominal Fan Speed	RPM	1250/1300/1350	1235/1345/1410	1235/1345/1410	836	843	823	833
Liquid/Suction Line OD								
	in	1/2/1 1/8	1/2/1 1/8	1/2/1 1/8	1/2/1 1/8	1/2/1 1/8	1/2/1 1/8	1/2/1 1/8
Approx. Operating Weight	kg	82	114	120	190	190	315	315
Unit Dimensions [uncrated]	HxWxD mm	396x1217x996	396x1593x995	396x1593x995	1423x1436x702	1423x1436x702	1673x1628x772	1673x1628x772

Notes

1 H= Horizontal Only. V=Verticle Only.

2 Per Motor @ 400V [std kW]

3 For direct drives only.



Performance Data (R22)

System Performance Matrix

MODEL		Evaporator Airflow		Total Capacity		Condenser Fan Motor	Total Compressor Motor
Outdoor	Indoor	CFM	CMH	MBH	kW	kW x Qty	kW
TTA 075	MCDP 075	2400	4078	84	25	0.55	6.9
TTA 100	MCDP 100	3235	5496	106	31	0.55	9.1
TTA 125	MCDP 125	3235	5496	127	37	0.55	10.2
2xTTA 075	TTH/V 150	4750	8070	168	49	0.55 x 2	13.8
TTA 075+100	TTH/V 175	5300	9005	190	56	0.55 x 2	16.0
2xTTA 100	TTH/V 200	6500	11044	212	62	0.55 x 2	18.3
2xTTA 125	TTH/V 240	8150	13847	254	74	0.55 x 2	20.4

Capacities based on ambient temperature of 95 F [35 C]. Coil on coil temperature of 80 / 67 F [26 / 19] EDB/EWB.
 Rated at 400V / 3P / 50 Hz
 Capacities are gross and do not include the evaporator fan motor heat deduction
 Custom Matches & configuration are available with the Trane Quantum Climate Changer air handler.

Odyssey System Performance Data																							
Entering Wet Bulb Model Combinations	CFM Airflow	Enter Dry Bulb (F)	Ambient Temperature, deg F																				
			75					95					105										
			61			67		73		61			67		73		61			67		73	
			MBH	SHC	MBH	SHC	MBH	SHC	MBH	SHC	MBH	SHC	MBH	SHC	MBH	SHC	MBH	SHC	MBH	SHC			
TTA075-MCDP075	2400	75	82.9	61.8	92.3	50.3	102.5	38.0	75	56	84	46	93	35	69.4	51.7	77.2	42.1	85.7	31.8			
		80	83.1	71.1	92.4	69.3	102.6	48.0	76	65	84	63	93	44	69.5	59.5	77.3	58.0	85.8	40.1			
		85	83.3	80.4	92.6	59.8	102.8	57.2	76	73	84	54	93	52	69.7	67.3	77.5	50.0	85.9	47.8			
		90	86.8	86.8	92.8	78.1	103.0	66.4	79	79	84	71	94	60	72.6	72.6	77.6	65.4	86.1	55.5			
TTA100-MCDP100	3235	75	105.6	83.0	116.4	65.5	127.8	47.6	96	75	106	60	116	43	88.3	69.4	97.3	54.8	106.9	39.8			
		80	105.9	96.6	116.6	88.0	128.0	61.6	96	88	106	80	116	56	88.6	80.8	97.5	73.6	107.1	51.5			
		85	108.1	108.1	116.8	92.8	128.4	75.4	98	98	106	84	117	69	90.4	90.4	97.7	77.6	107.4	63.1			
		90	113.7	113.7	117.3	106.5	128.7	89.4	103	103	107	97	117	81	95.1	95.1	98.1	89.1	107.7	74.8			
TTA125-MCDP125	3235	75	129.6	118.6	139.2	78.6	153.4	57.0	118	108	127	71	139	52	108.4	99.2	116.5	65.8	128.3	47.7			
		80	129.6	118.6	139.7	97.9	153.7	74.0	118	108	127	89	140	67	108.4	99.2	116.8	81.9	128.5	61.9			
		85	132.6	132.6	139.9	111.7	154.3	90.9	121	121	127	102	140	83	110.9	110.9	117.0	93.4	129.1	76.0			
		90	139.7	139.7	140.6	128.0	154.8	107.6	127	127	128	116	141	98	116.8	116.8	117.6	107.1	129.5	90.0			
2xTTA075-TTH/V150	4750	75	165.9	123.6	184.7	100.7	204.9	76.1	151	112	168	92	186	69	138.7	103.4	154.5	84.2	171.4	63.6			
		80	166.1	142.3	184.8	138.6	205.3	96.0	151	129	168	126	187	87	138.9	119.0	154.6	115.9	171.7	80.3			
		85	166.6	160.9	185.3	119.7	205.5	114.4	151	146	168	109	187	104	139.3	134.6	155.0	100.1	171.9	95.7			
		90	173.5	173.5	185.5	156.3	206.0	132.8	158	158	169	142	187	121	145.1	145.1	155.2	130.7	172.3	111.1			
TTA075+100-TTH/175	5300	75	188.5	144.8	208.7	115.8	230.3	85.7	171	132	190	105	209	78	157.7	121.1	174.6	96.9	192.6	71.6			
		80	189.0	167.7	209.0	157.3	230.7	109.6	172	152	190	143	210	100	158.1	140.3	174.8	131.6	192.9	91.6			
		85	191.4	188.6	209.5	152.7	231.1	132.6	174	171	190	139	210	121	160.1	157.7	175.2	127.7	193.9	110.9			
		90	200.5	200.5	210.1	184.7	231.7	155.8	182	182	191	168	211	142	167.7	167.7	175.7	154.4	193.8	130.3			
2xTTA100-TTH/V200	6500	75	211.2	165.9	232.7	131.0	255.6	95.3	192	151	212	119	232	87	176.6	138.8	194.7	109.5	213.8	79.7			
		80	211.9	193.2	233.2	176.0	256.1	123.2	193	176	212	160	233	112	177.2	161.6	195.0	147.2	214.2	103.0			
		85	216.3	216.3	233.7	185.7	256.8	150.9	197	197	212	169	233	137	180.9	180.9	195.4	155.3	214.7	126.2			
		90	227.5	227.5	234.6	213.0	257.5	178.8	207	207	213	194	234	163	190.3	190.3	196.2	178.2	215.3	149.5			
2xTTA125-TTH/V240	8150	75	259.2	237.2	278.5	157.3	306.9	113.9	236	216	253	143	279	104	216.8	198.4	232.9	131.5	256.6	95.3			
		80	259.2	237.2	279.4	195.8	307.3	148.0	236	216	254	178	279	135	216.8	198.4	233.7	163.8	257.0	123.8			
		85	265.1	265.1	279.9	223.4	308.7	181.8	241	241	254	203	281	165	221.7	221.7	234.1	186.9	258.2	152.1			
		90	279.4	279.4	281.3	256.0	309.6	215.2	254	254	256	233	281	196	233.7	233.7	235.2	214.1	259.0	180.0			

1 Dry coil condition. Total Gross Cooling Capacity (MBh) show to the left is not applicable.
 In this case the Sensible Heat Capacity (SHC) is the total capacity
 All capacities shown are gross and have not considered indoor fan heat.
 To obtain net cooling capacities subtract indoor fan heat.
 MBH = Total Gross Cooling Capacity
 SHC = Sensible Heat Capacity

Fan Performance Tables

[belt drive]

TTH/V 150																															
Ext. Static Pressure	0.10" wg	0.15" wg	0.2" wg	0.25" wg	0.30" wg	0.35" wg	0.4" wg	0.50" wg	0.6" wg	0.75" wg	1.0" wg	1.25" wg	1.50" wg	1.75" wg	2.00" wg																
TTH/V 150 (RPM836)	25Ps	38Ps	50Ps	63Ps	75Ps	88Ps	100Ps	125Ps	150Ps	188Ps	250Ps	312Ps	375Ps	438Ps	500Ps																
FC 15x15	CFM																														
	3,800	714	0.90	730	0.94	746	0.97	762	1.00	777	1.04	791	1.08	805	1.11	834	1.18	862	1.27	904	1.38	973	1.57	1042	1.80	1110	2.12	1179	2.30	NA	NA
	4,275	718	1.09	734	1.13	749	1.16	763	1.18	777	1.23	791	1.25	805	1.29	834	1.37	862	1.44	901	1.57	964	1.78	1026	1.99	1087	2.21	1146	2.45	NA	NA
	4,750	724	1.30	739	1.34	754	1.38	769	1.42	783	1.46	797	1.49	811	1.53	836	1.60	862	1.68	901	1.79	963	2.00	1021	2.24	1078	2.47	1133	2.70	1189	2.94
	5,225	728	1.52	743	1.57	759	1.62	773	1.68	787	1.70	801	1.74	815	1.79	842	1.87	868	1.96	905	2.08	963	2.29	1022	2.50	1077	2.75	1129	3.00	1180	3.76
5,700	755	1.84	762	1.85	770	1.89	780	1.92	791	1.96	805	2.02	820	2.07	847	2.17	872	2.26	910	2.40	969	2.63	1023	2.85	1078	3.08	1120	3.32	1185	3.59	
yellow cell = oversize motor 4.0 kw (OS 2)																															
TTH/V 175																															
FC 15x15	4,240	608	0.96	734	1.02	748	1.14	762	1.18	777	1.21	791	1.24	806	1.28	834	1.35	862	1.43	901	1.55	964	1.76	1026	1.97	1058	2.18	1150	2.44	NA	NA
	4,770	724	1.07	739	1.35	754	1.39	769	1.43	783	1.47	797	1.50	811	1.54	837	1.62	862	1.69	901	1.60	963	2.10	1021	2.25	1077	2.48	1133	2.71	1185	2.95
	5,330	730	1.56	744	1.60	759	1.66	774	1.70	788	1.75	802	1.79	816	1.83	843	1.92	869	2.01	906	2.13	964	2.34	1021	2.55	1077	2.79	1129	3.05	1180	3.22
	5,830	766	1.95	772	1.97	779	1.99	787	2.02	796	2.05	807	2.09	820	2.14	848	2.25	874	2.35	911	2.49	971	2.73	1025	2.95	1077	3.18	1129	3.43	1180	3.69
	6,380	NA	NA	NA	NA	NA	NA	830	2.51	835	2.53	840	2.55	848	2.57	860	2.62	879	2.71	917	2.89	975	3.15	1031	3.41	1063	3.57	1132	3.91	1179	4.16
yellow cell = oversize motor 4.0 kw (OS 2)																															
TTH/V 200																															
FC 18x18	5,200	689	1.55	704	1.61	719	1.67	734	1.73	750	1.80	766	1.87	782	1.94	813	2.10	843	2.26	887	2.51	957	2.94	1019	3.33	1074	3.71	NA	NA	NA	NA
	5,850	686	1.77	697	1.82	706	1.87	719	1.92	730	1.98	742	2.04	753	2.10	776	2.22	804	2.35	845	2.57	916	2.99	962	3.46	1045	3.94	NA	NA	NA	NA
	6,500	692	2.05	703	2.11	713	2.16	724	2.21	734	2.26	744	2.32	754	2.37	774	2.49	793	2.60	823	2.79	876	3.13	941	3.53	1004	3.99	1064	4.50	NA	NA
	7,150	697	2.38	708	2.43	718	2.49	729	2.55	740	2.61	750	2.67	760	2.72	779	2.84	779	2.95	825	3.13	870	3.45	916	3.79	967	4.18	1024	4.61	1081	5.10
	7,800	705	2.77	715	2.82	725	2.88	735	2.93	744	2.99	754	3.05	764	3.11	784	3.24	784	3.36	831	3.55	875	3.87	916	4.20	957	4.55	1000	4.93	NA	NA
yellow cell = oversize motor 5.5 kw (OS 2)																															
TTH/V 240																															
FC 18x18	6,400	691	2.01	702	2.06	713	2.11	723	2.16	733	2.22	743	2.27	753	2.33	773	2.44	793	2.56	824	2.75	883	3.10	947	3.51	1010	3.96	1071	4.5	NA	NA
	7,200	697	2.40	708	2.46	719	2.52	729	2.58	740	2.64	750	2.69	760	2.75	780	2.87	799	2.99	825	3.16	870	3.48	916	3.82	965	4.26	1021	4.62	1078	5.1
	8,000	708	2.90	718	2.96	728	3.01	737	3.07	747	3.13	757	3.18	765	3.24	785	3.37	805	3.50	833	3.89	877	4.02	958	4.34	958	4.89	996	5.05	NA	NA
	8,800	721	3.45	730	3.51	740	3.58	748	3.64	759	3.71	768	3.78	785	3.85	795	3.97	813	4.10	838	4.29	883	4.63	825	4.99	NA	NA	NA	NA	NA	NA
	9,600	745	4.18	752	4.21	759	4.28	766	4.31	774	4.37	782	4.44	807	4.50	807	4.65	825	4.80	851	5.02	NA	NA	NA	NA	NA	NA	NA	NA	NA	NA
yellow cell = oversize motor 5.5 kw (OS 2)																															



Fan Performance Tables [Direct Drive]

MCDP 075

KD2 9/7 750W 4P - 13SF

Low Speed				
ESP (Pa)	51	37	23	5
m3/hr	3950	4000	4025	4050
cfm	2325	2354	2369	2384

Medium Speed										
ESP (Pa)	182	168	153	138	124	103	77	51	34	17
m3/hr	3100	4050	4100	4150	4200	4250	4300	4350	4450	4500
cfm	1825	2384	2413	2443	2472	2501	2531	2560	2619	2649

Hi - Speed																		
ESP (Pa)	263	253	243	234	224	214	204	192	179	167	154	138	120	100	80	70	60	50
m3/hr	2000	2500	2550	2750	2800	2950	3000	3300	4250	4500	4600	4650	4700	4750	4800	4850	4900	4950
cfm	1177	1471	1501	1619	1648	1736	1766	1942	2501	2649	2707	2737	2766	2796	2825	2855	2884	2913

MCDP 100

KD2 9/9 1100W 4P - 13SF

Low Speed				
ESP (Pa)	158	116	56	8
m3/hr	3900	4700	4950	-
cfm	2295	2766	2913	

Medium Speed									
ESP (Pa)	238	226	213	200	187	175	157	111	53
m3/hr	2800	3500	3900	4100	4400	5200	5350	5650	-
cfm	1648	2060	2295	2413	2590	3061	3149	3325	

Hi - Speed																
ESP (Pa)	248	243	240	237	232	220	208	197	180	160	140	125	100	84	70	50
m3/hr	1900	2500	2800	4000	4100	4400	4900	5500	5900	6100	6300	-	-	-	-	-
cfm	1118	1471	1648	2354	2413	2590	2884	3237	3473	3590	3708					

MCDP 125

KD2 9/9 1100W 4P - 13SF

Low Speed				
ESP (Pa)	158	116	56	8
m3/hr	3400	4200	4900	-
cfm	2001	2472	2884	-

Medium Speed									
ESP (Pa)	238	226	213	200	187	175	157	111	53
m3/hr	1000	1900	2800	3500	3700	3900	4300	5500	5750
cfm	589	1118	1648	2060	2178	2295	2531	3237	3384

Hi - Speed																
ESP (Pa)	248	243	240	237	232	220	208	197	180	160	140	125	100	84	70	50
m3/hr	500	550	700	750	800	1900	2500	4100	4800	5700	6000	6100	6350	-	-	-
cfm	294	324	412	441	471	1118	1471	2413	2825	3355	3531	3590	3737	-	-	-

Condensing Unit Performing Curves

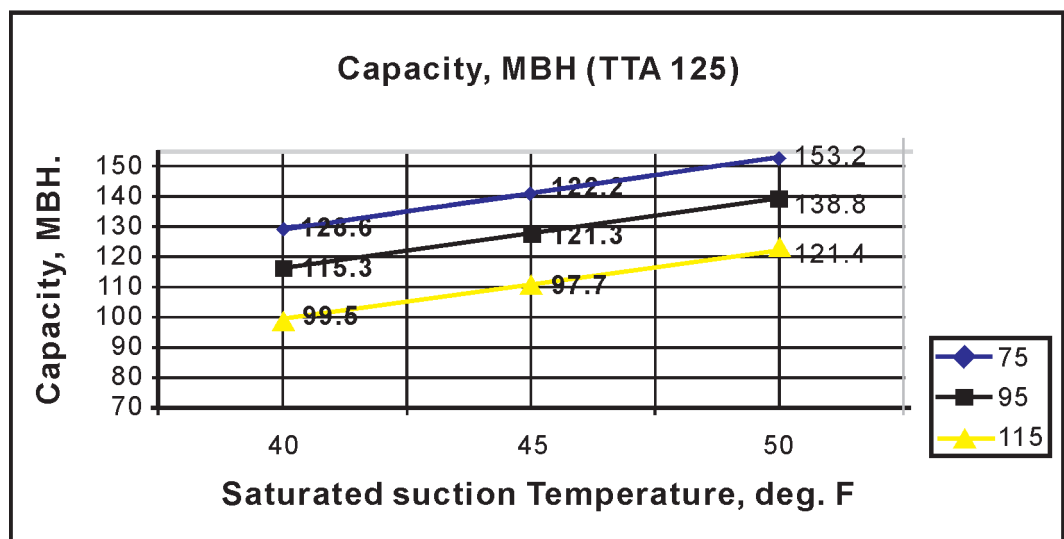
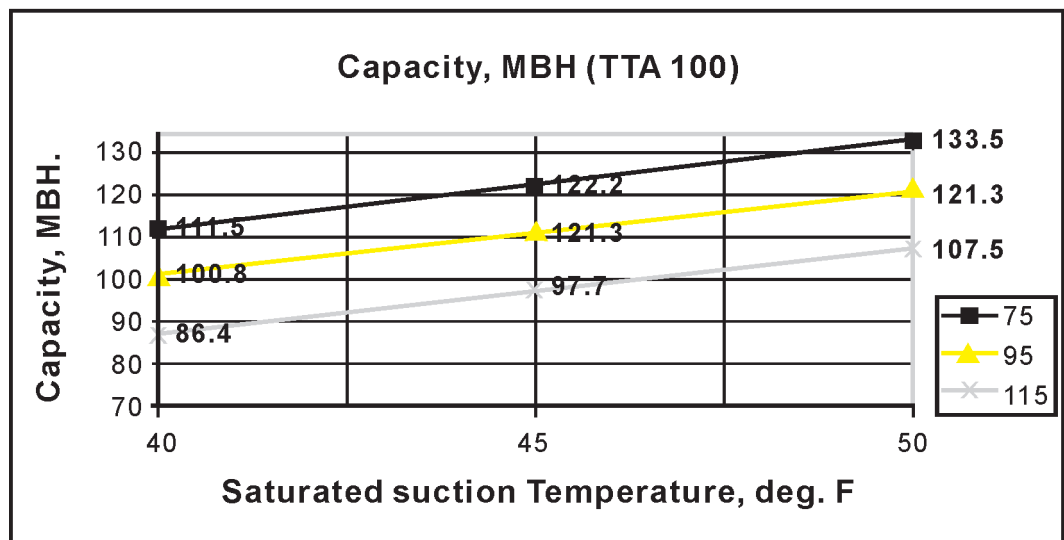
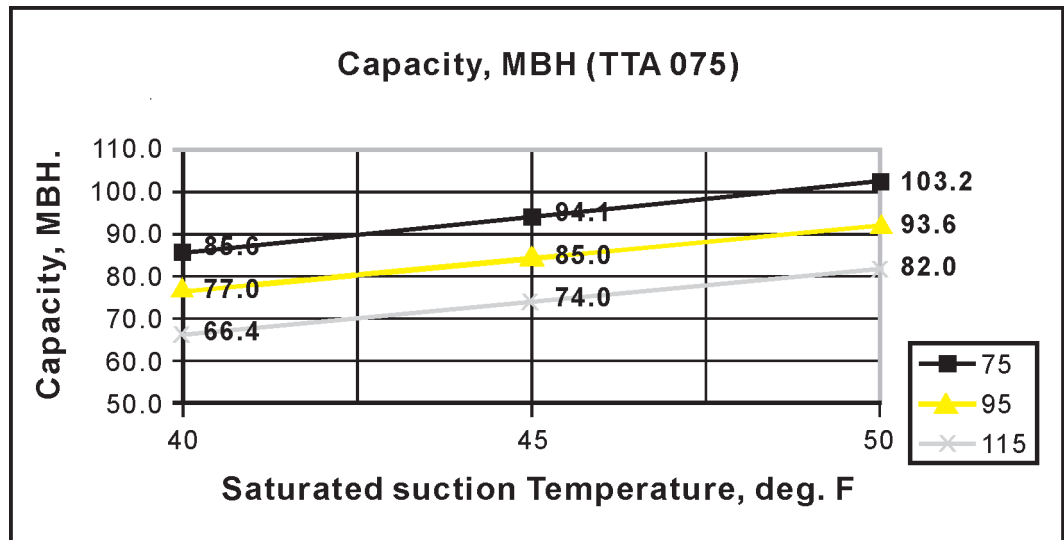

Application Considerations

Clearance Requirements

The recommended clearance identified with unit dimensions should be maintained to assure adequate serviceability, maximum capacity and peak operating efficiency. Actual clearance which appear inadequate should be reviewed with the local Trane Representative.

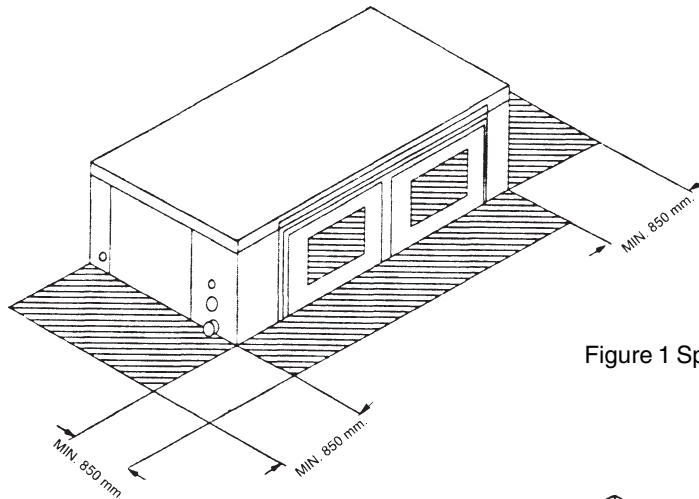

Figure 1 Space requirement for MCDP & TTH models

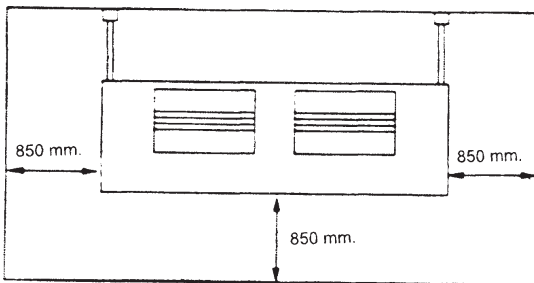

Figure 2 Space requirement for TTH model - Horizontal Type

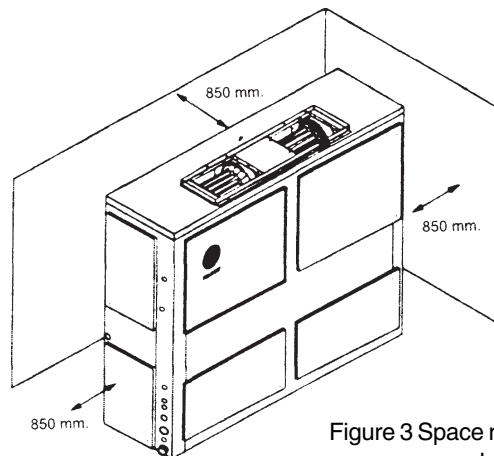

Figure 3 Space requirement for TTV model - Vertical Type

Recommended Interconnecting Lines - Condensing Units

Model	Length of Interconnection Line (feet)							
	0-20		21-40		41-60		61-80	
	Ltq.	Suct.	Ltq.	Suct.	Ltq.	Suct.	Ltq.	Suct.
TTA075SD	1/2	1 1/8	1/2	1 1/8	1/2	1 1/8	1/2	1 1/8
TTA100SD	1/2	1 1/8	1/2	1 1/8	1/2	1 1/8	1/2	1 3/8
TTA125SD	1/2	1 1/8	1/2	1 1/8	1/2	1 1/8	1/2	1 3/8

Notes: For line lengths over 80 linear feet and 15 feet liquid line riser, consult your local Trane representative.

Dimensional Data

TTA 075-125

VERTICAL DISCHARGE

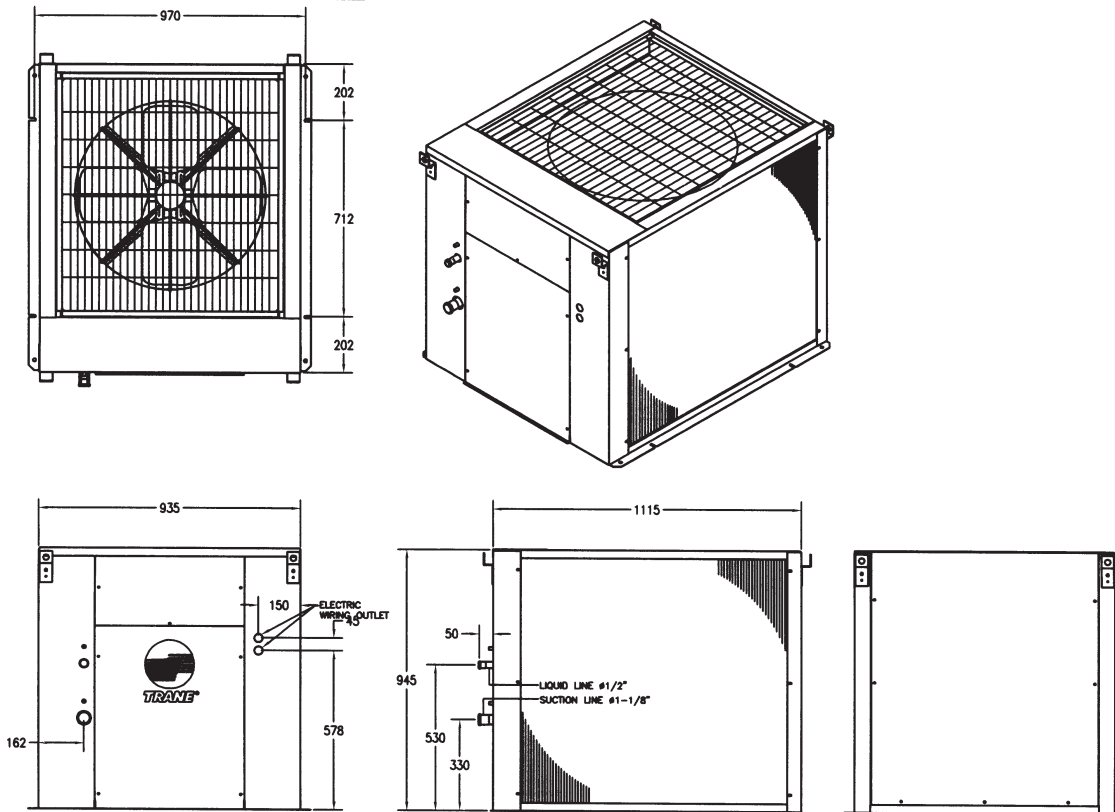

HORIZONTAL DISCHARGE

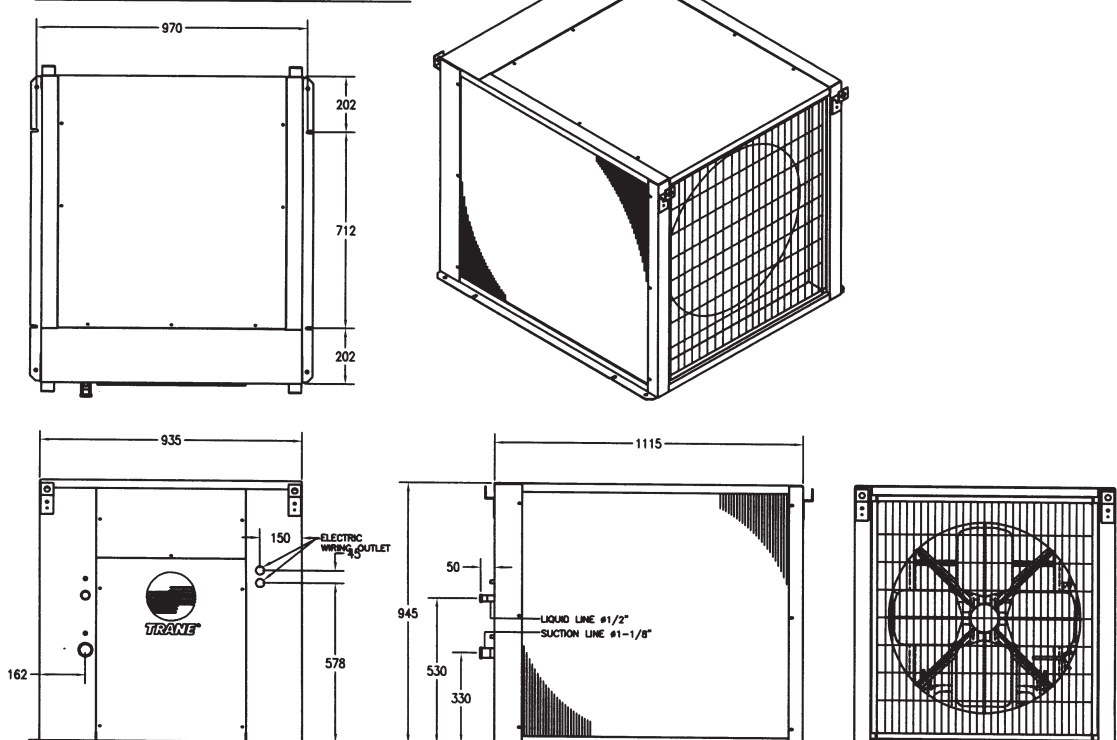

Dimensional Data (MCDP 075-125)

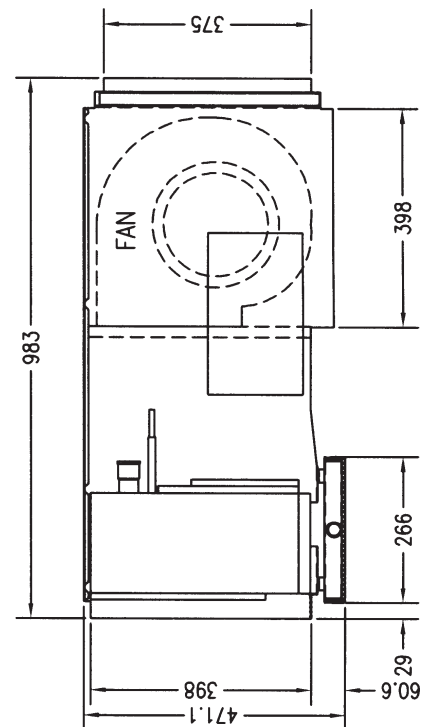
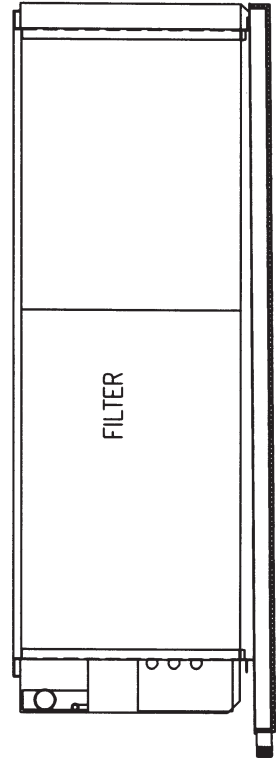
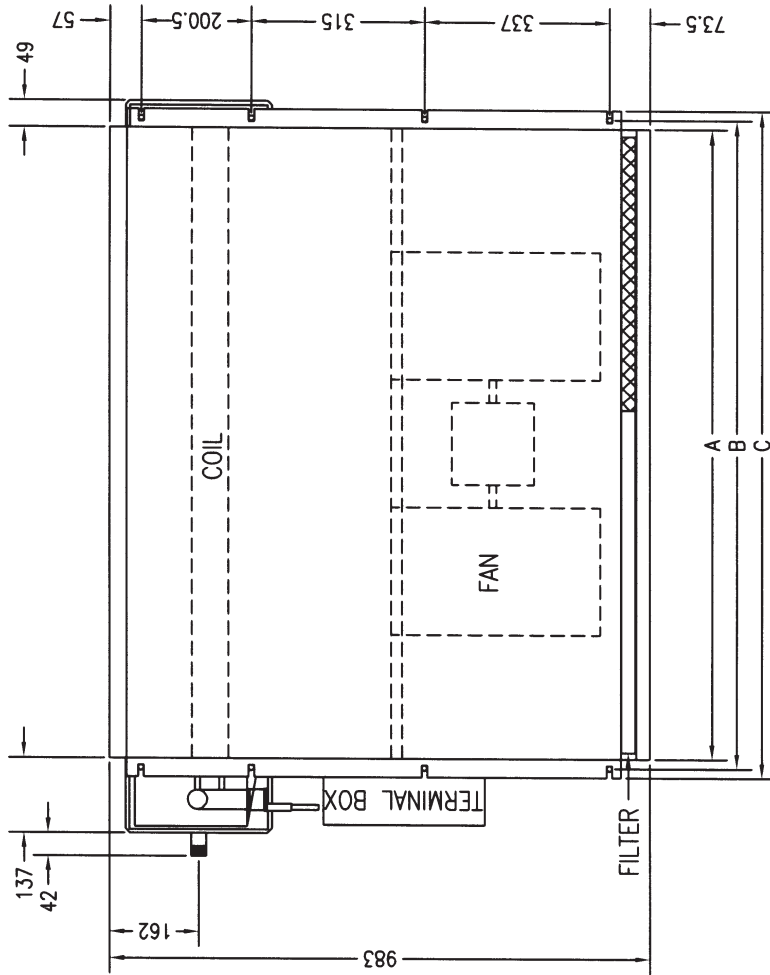

MODEL	A	B	C
075	1143	1182.5	1216.5
100/120	1524	1558.5	1592.5

Dimensional Data

TTH 150-175

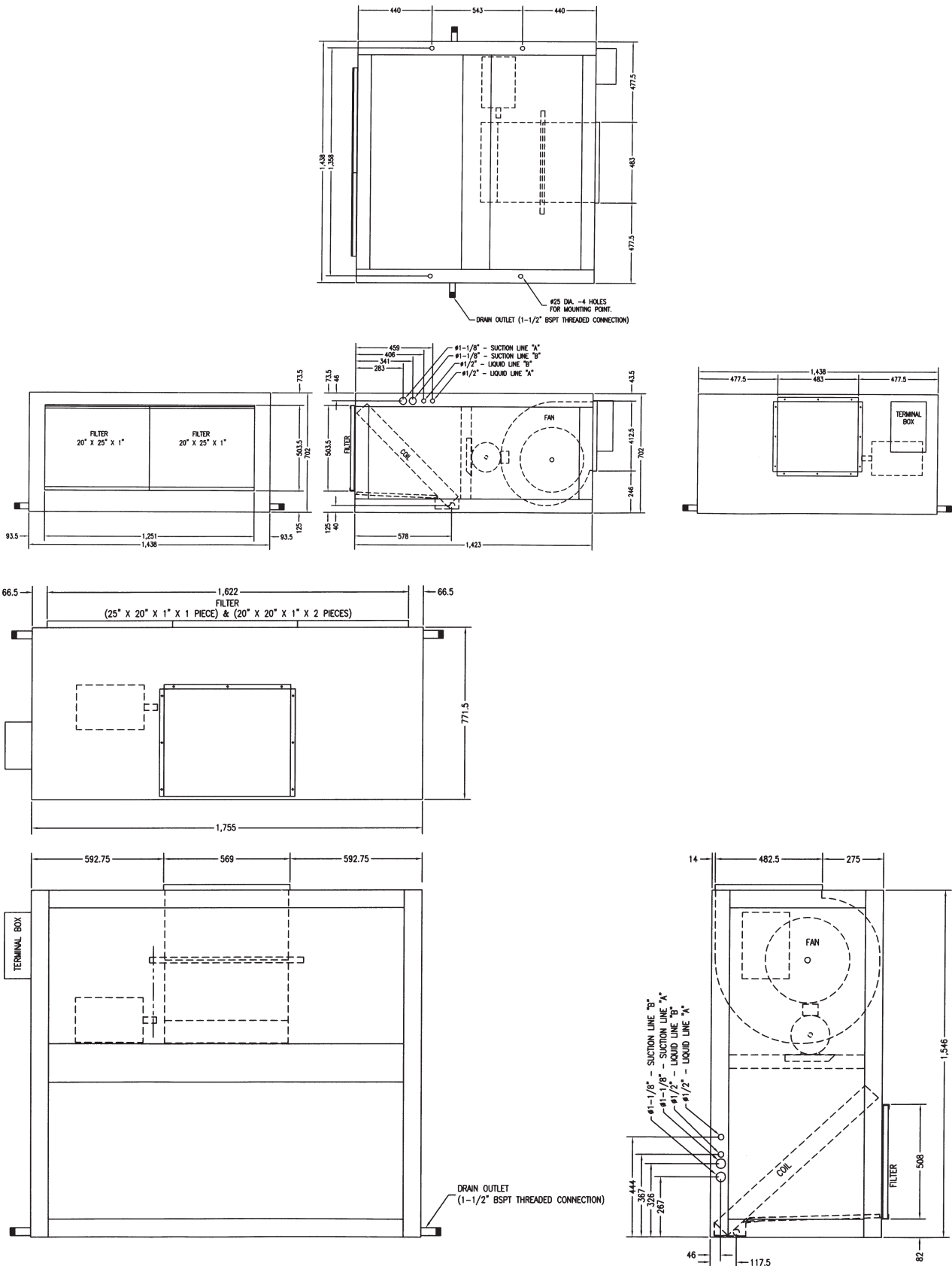

Dimensional Data (TTH/V 200-240)

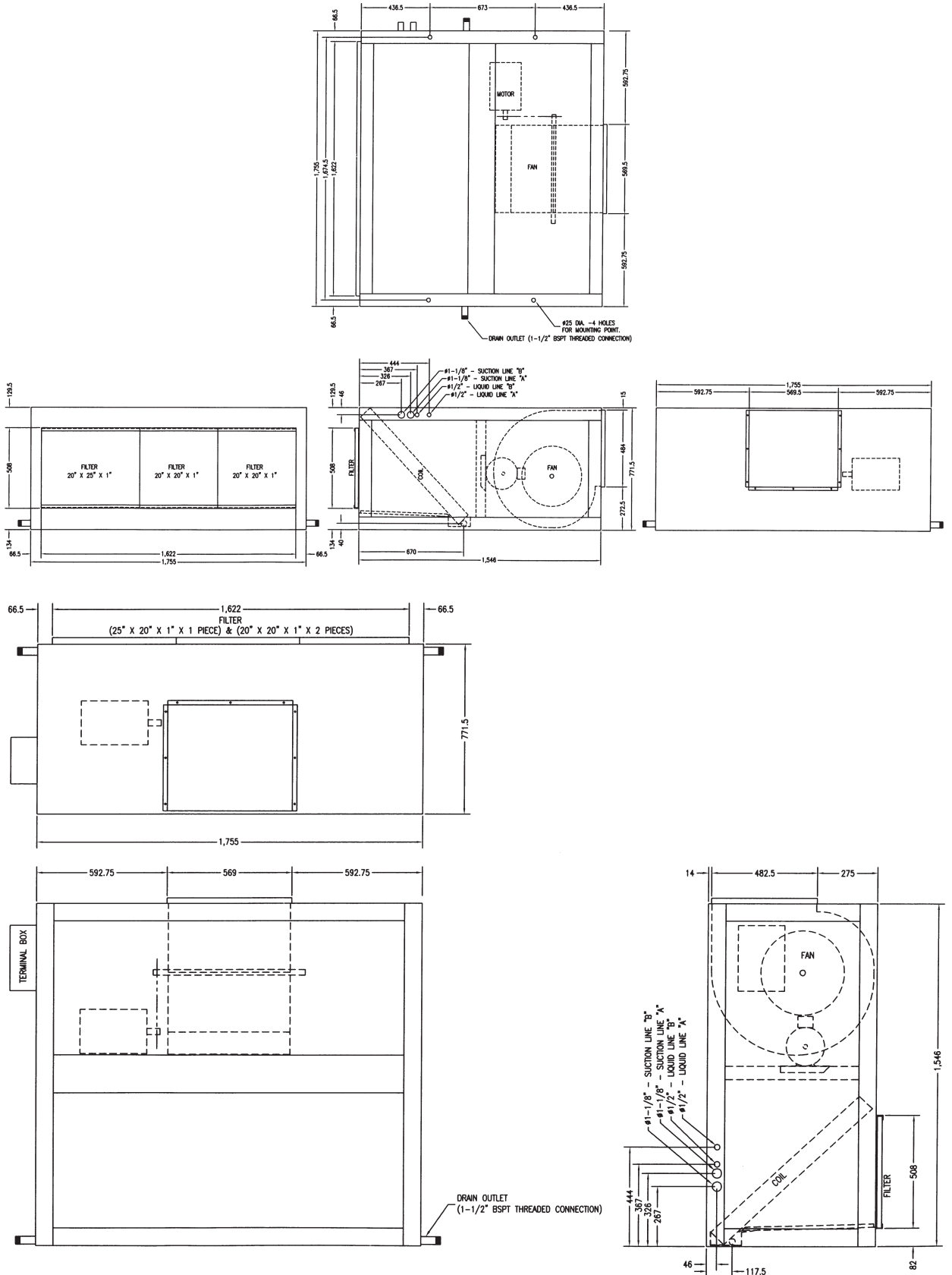

System Wiring (TTA-MCDP)

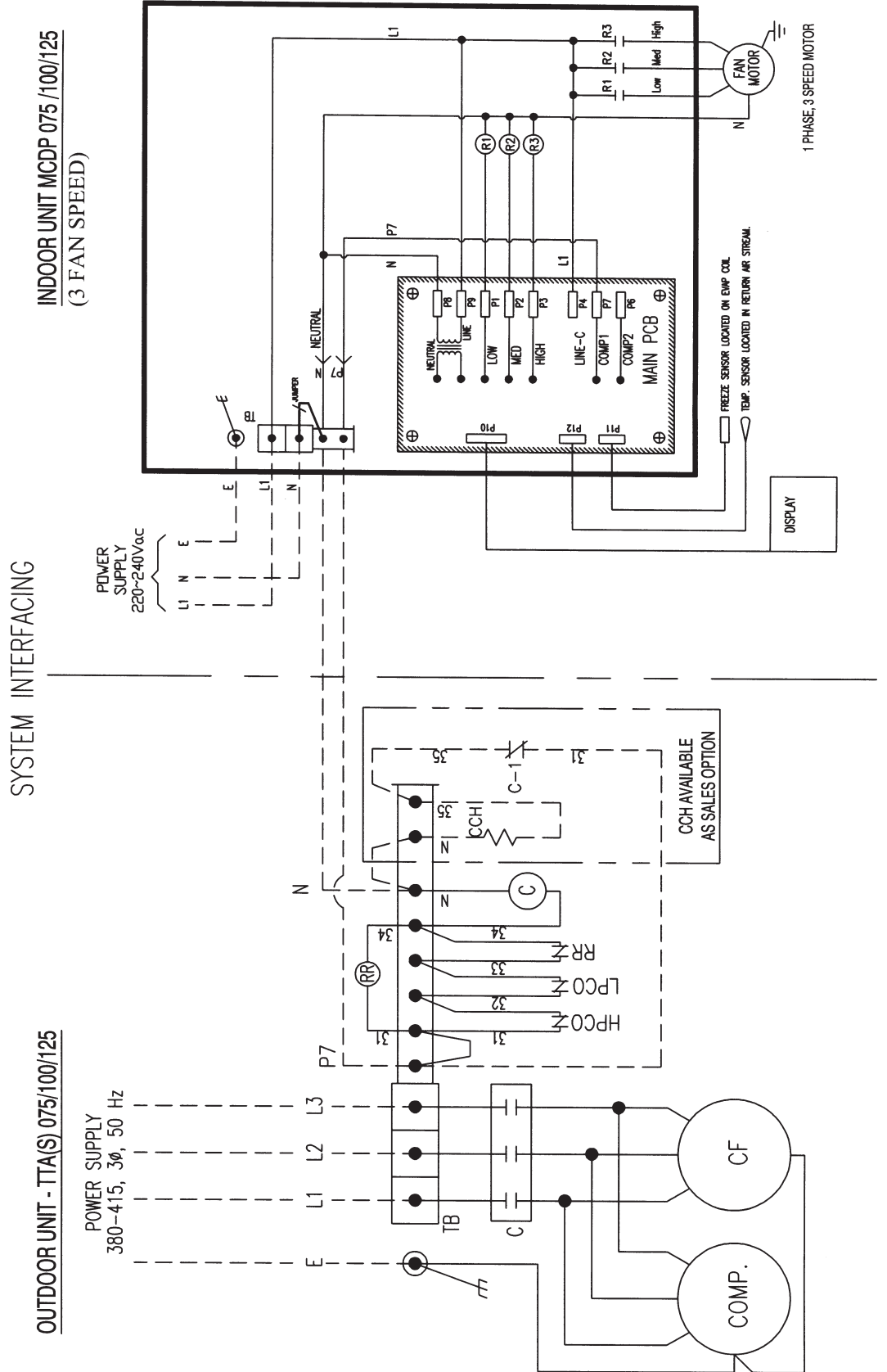

System Integration

- 1 = Open space Comfort: AHU with factory-mounted control MP581.
- 2 = Variable air volume damper: VariTrane™ + VV550

1 = Open space Comfort: AHU with factory-mounted control MP581
2 = Variable air volume damper: VariTrane™ + VV550

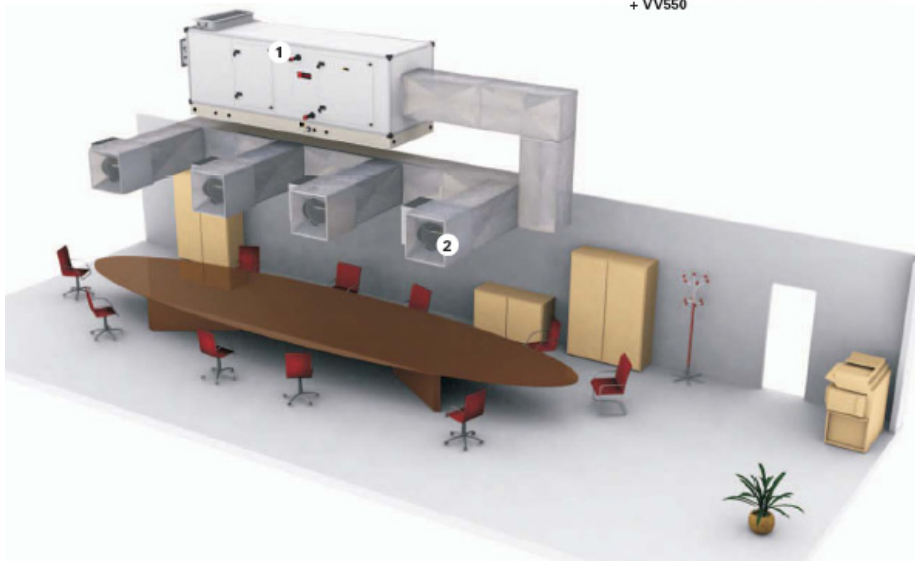

Trane, as a HVAC systems company has the unique ability to offer a complete systems solution to virtually any building.

The Trane condensing units, can be custom matched up with the Trane Climate Changer AHUs offering renowned for its air-systems flexibility, as well as system level integrated controls.

Specilized Applications include:

100% Fresh Air, clean room filtration, heat recovery, humidity control, full Trane factory installed controls...



Mechanical Specifications Condensing Units

General

The condensing unit shall be assembled on heavy gauge steel supports, and shall be weather proofed. Units shall include a hermetic scroll compressor, slit fin condenser coil, a fan and motor. Controls shall be rated in accordance with ARI Standard 210 and 270. All condensing units shall be modular to facilitate easy installation and system upgrade.

Casing

The unit casing shall be constructed of 18 gauge zinc coated heavy gauge galvanized steel. Exterior surfaces shall be cleaned, phosphatized and finished with a polyester powder paint. Unit surface shall be tested to 500 hours in a salt spray test. Units shall have removable end panels which allow easy access to all major components and controls. The casing construction and design shall allow for a site conversion to horizontal discharge with no hardware change.

Refrigerant Circuit

Each condensing unit shall have a single compressor on a single circuit. The circuits are assembled, pressure tested, and charged with dry nitrogen... Each circuit includes the following components (see below):

Gauge Ports

Each unit shall have both a liquid line and a suction gas line gauge port for external servicing.

Condenser

Two condenser coils per circuit made of Aluminum slit fin to copper tubes, with an integral sub-cooling circuit. Each coil shall be easily accessed for cleaning and maintenance from the left and right hand side of the unit. Tubes

shall be 3/8" copper, mechanically bonded to configured W3BS aluminum plate fins. Coils shall be factory pressure and leak tested to 450psig air pressure. Optional corrosion resistant fins are optional.

Compressor

Each unit shall have an internally vibration isolated scroll compressor per circuit. The scroll compressor shall have the following features as standard:
Internal Line Break Motor Protection.
Suction Gas Motor Cooling
Suction Screen
Disc Type Check Valve
Centrifugal Oil Pump with Filter and Magnet
DU (PTFE) Journal Bearings

Electrical Connections

All units come factory fitted and tested with standard Direct on line starters. Each condensing unit shall have a time delay relay as standard to protect the compressor. The control of the unit is from the thermostat control located within the standard indoor unit. The voltage utilization range for operation shall be 400V, +, -10%, 50Hz, 3 phase.

Condenser Fan and Motor

A direct drive, statically and dynamically balanced 26" propeller fan with aluminum blades, and electro-coated steel hubs shall be used in a draw through vertical or horizontal discharge configuration.

Each, permanently lubricated totally enclosed construction motor shall have an IP rating of IP 44, with built in current of thermal overload protection. Motors shall have either a ball or sleeve bearing type.

Ambient Temperature

The condensing unit shall operate up to a 45 C ambient temperature, and for high ambient requirements, with a high ambient option, the operation is up to 50 C ambient.

Mechanical Specifications

Indoor Units

General

All indoor units shall be completely factory assembled including coil, condensate drain pan, fan motor, filters and controls in an insulated casing. Models TTh 75-125 shall be dedicated horizontal application, depending on the ordered configuration. Units shall be rated and tested in accordance to ARI standard 210.

Casing

Units casing shall be constructed of zinc coated, heavy gauge, galvanized steel. Exterior surfaces shall be cleaned, phosphatized and finished with a polyester powder paint. Casing shall be thermally insulated with fiberglass free non hydroscopic PE insulation. For blow through units TTH 075-125, intake sections before the coil shall be acoustically insulated with PU foam sheets. Knockouts shall be provided for unit electrical power and refrigerant piping connections.

Refrigeration System

TTH 075-125 shall have a single circuit while models 150-240 shall have 2 circuits. Each circuit shall be controlled by a fixed flow expansion device on the TTH 075-100 and TTH/V150, while TXVs are installed on models 175-240.

Evapo

Configured aluminum fin surface shall be mechanically bonded to 3/8" copper tubing and factory pressure and leak tested to 375 psig. Trane Wany 3BS fins shall be provided to eliminate moisture carryover possibilities and maximize efficiency. Drain pans shall be PE insulated, and corrosion proofed with bitumen coated galvanized iron.

Evaporator Fan

Double inlet, double width, forward curved, centrifugal type fan (s) with belt

drive, 3 phase motors for models TTH/V 150-240 and direct drive with integrated 1 phase, 3 speed motors for direct drive blow through TTH 075-125. Thermal overload protection shall be standard on all motors. Fan and motor bearings shall be permanently lubricated.

Controls

Magnetic evaporator direct on line evaporator fan contactors on a 220V terminal strip and single point power entry shall be included. All necessary controls shall be factory installed and wired including thermostat control cards and wired thermostat controller.

The factory supplied thermostat controller, shall come with a 3 speed controller for the TTH 075-125 3 speed motors, and speed settings shall be fixed for larger belt driven models. Controllers shall have an integrated timer, night setback, freeze protection, and on - off switch.

Filters

One inch, synthetic washable filters shall be standard on all units. Filters shall be side accessible.



Trane

www.trane.com

For more information, contact your local district office



Literature Order Number SS-PRC025-EN (April 2009)

File Number

Supersedes SS-PRC025-EN (December 2008)

Stocking Location Malaysia

Trane has a policy of continuous product and product data improvement and reserves the right to change design and specifications without notice. Only qualified technicians should perform the installation and servicing of equipment referred to in this publication.