

Offer Solution, Sell Value



CLCP Features- Sell Value

Energy Recovery Component

A. Heat Recovery(100% EA & FA)

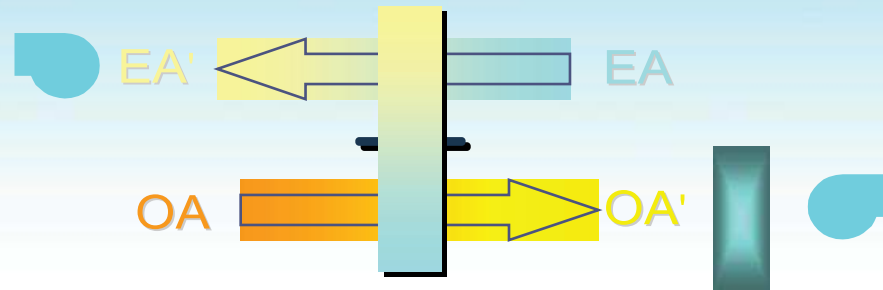

B. Free Sensible Heating

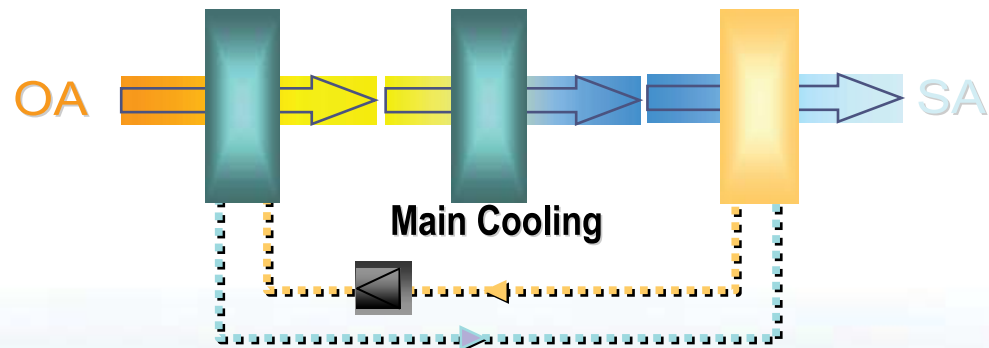

CLCP Features- Sell Value

Energy Recovery Component

A. Heat Recovery(100% EA & FA)

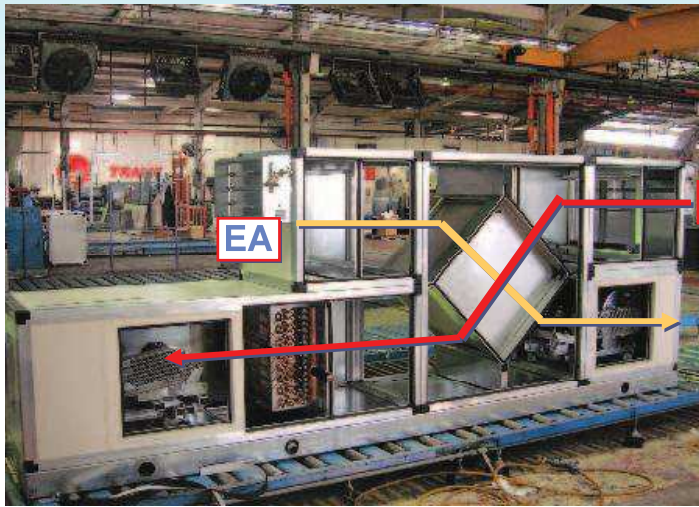
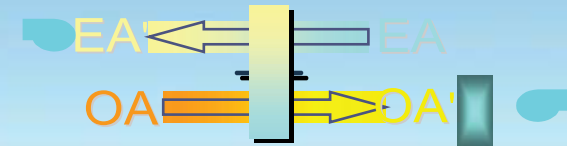

EA

OA



EA

OA

Fixed Plate HX



Heat Recovery Wheel



CLCP Features- Sell Value

Energy Recovery Component

A. Heat Recovery(100% EA & FA)

Coil Loop and Heat Pipe

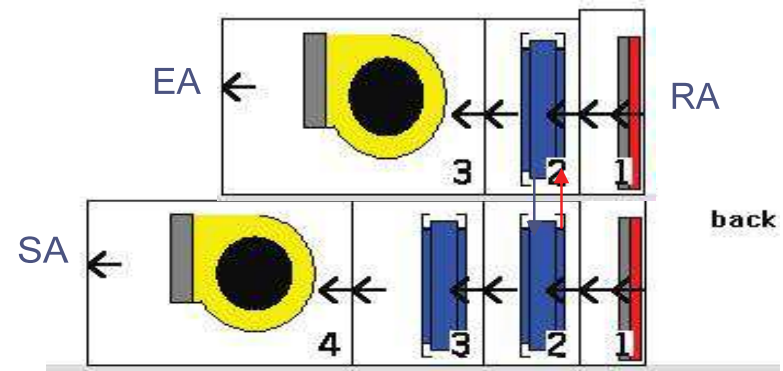
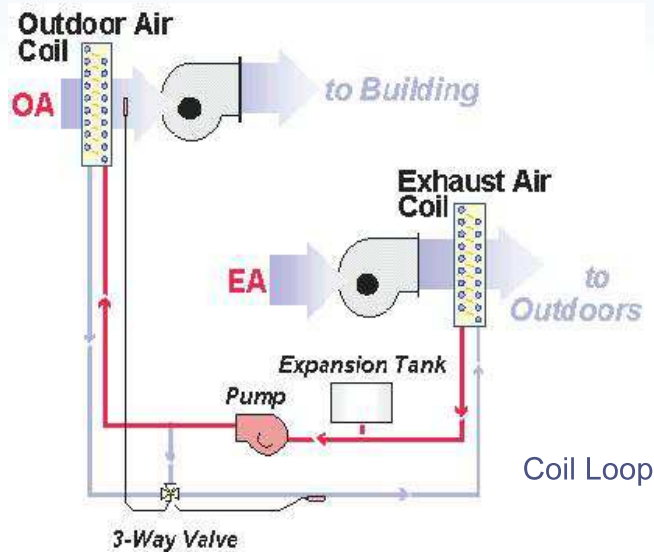
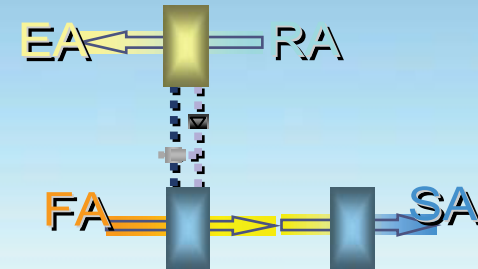

Typical AHU Configuration



CLCP Features- Sell Value

Energy Recovery Component

B. Free Sensible Heating Coil Loop and Heat Pipe

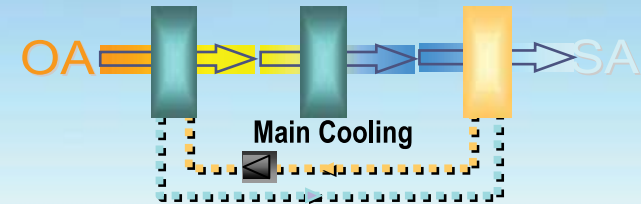

Jobsite piping connection of
Coil Loop



Heat Pipe



CLCP Features - Sell Value

Cool Dry Quiet [CDQ] Humidity Control System

Humidity control 24/7, 365 days per year-1000-25000 cfm

CDQ can lower the indoor humidity & improve IAQ

5 - 15 F (3- 8°C) lower dew point than cooling coil [CW & DX]

Reduce energy cost of dehumidification

20%- 80% reduction in reheat and cooling energy

Vertical Markets

Galleries, Museums, Archives,

Hotels,

Hospitals,

Process Applications

